



Case Study

REDUCING AIR CONSUMPTION USING HIGH FLOW AIR ATOMIZING NOZZLES
STEEL INDUSTRY



FLUE GAS COOLING SOLUTION

Cooling of exhaust gases from the Electric Arc Furnace (EAF) is critical to controlling temperatures of the gas in the ductwork as it enters the baghouse to prevent a fire. Air atomizing nozzles are ideal for cooling the gases because they produce very fine droplets, but air consumption can be high and costly if the proper nozzle is not selected.

► PROBLEM: HIGH CONSUMPTION OF COMPRESSED AIR

A leading Steel Mill was using lake water to quench exiting hot flue gas. The goal was to cool the flue gas to 350°F through evaporative cooling. The customer's current process utilized five twin-fluid, air atomizing nozzles from another spray manufacturer. Twin-fluid nozzles require both air and liquid for atomization to occur. The flow rate for each nozzle was 20gpm. The total pressure required for each nozzle was 50psi (air) and 60psi (water). The total amount of atomizing air calculated for this application was 93 SCFM.

These twin-fluid nozzles consumed too much compressed air, and the customer was unsatisfied because of the high costs. They wanted to know if they could switch from a twin-fluid nozzle to a single-fluid nozzle so compressed air would no longer be required.

► SOLUTION: SPIRALAIR® SA HIGH FLOW AIR ATOMIZING NOZZLES

The customer contacted BETE for a better spray quenching solution and expressed their concern about the amount of compressed air consumed in their current process. The engineers at BETE compared the single fluid spiral TF nozzle with the twin-fluid SpiralAir SA nozzle to see which option was better. For this spray application type, smaller droplet sizes are essential for effective quenching and cooling of gases, so BETE determined that air atomization was still the best solution. Air atomizing nozzles produce smaller droplet sizes at higher flow rates and lower fluid pressures than single-fluid nozzles. Although compressed air is still required, the selected SpiralAir SA nozzle will significantly reduce consumption.





Results

BETE's SpiralAir SA twin fluid nozzles have an equivalent liquid flow rate, which only consumed 1/3 of the amount of air compared to the customer's original twin-fluid nozzle while operating at nearly the same fluid and air pressure. This increase in efficiency is an estimated savings of \$2,600 per year in air costs.

The SpiralAir SA with 1-1/2" connection and set-up number 2301-B has a flow rate of 20 gpm and requires 50 psi air / 61 psi water. The total amount of atomized air reduction went from 93 SCFM to 30 SCFM. BETE's skilled team designed and fabricated a spray assembly to replace the customer's existing spray technology using five performance SpiralAir SA nozzles.

ADVANTAGE OF THE SPIRALAIR® SA HIGH FLOW AIR ATOMIZING NOZZLES

- A three-stage process that uses atomizing air more efficiently than conventional designs
- Two-phase atomization for highest performance
- Efficient design reduces compressed air consumption
- Designed for high reliability in extremely hostile environments

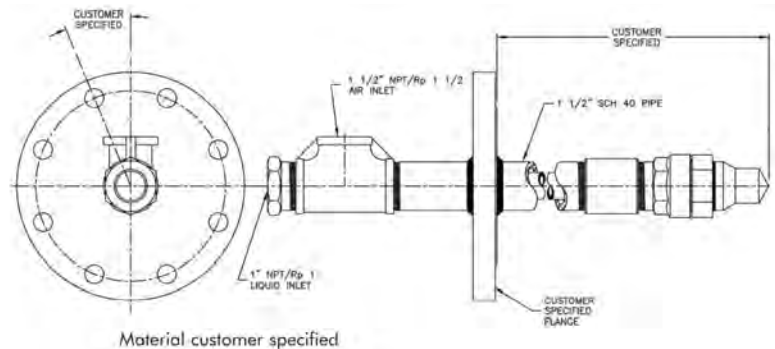

SPRAY NOZZLE & SPRAY SYSTEMS EXPERTS

- ISO 9001:2015 Certified
- The ability to solve unique and complex process challenges
- Trusted nozzle design and manufacturing with consistent quality assurance

BETE is an innovation leader in the development and manufacturing of specialized spray technology solutions.

50 Greenfield Street,
Greenfield, MA 01301 USA

800-235-0049
413-772-0846

www.BETE.com
sales@BETE.com